

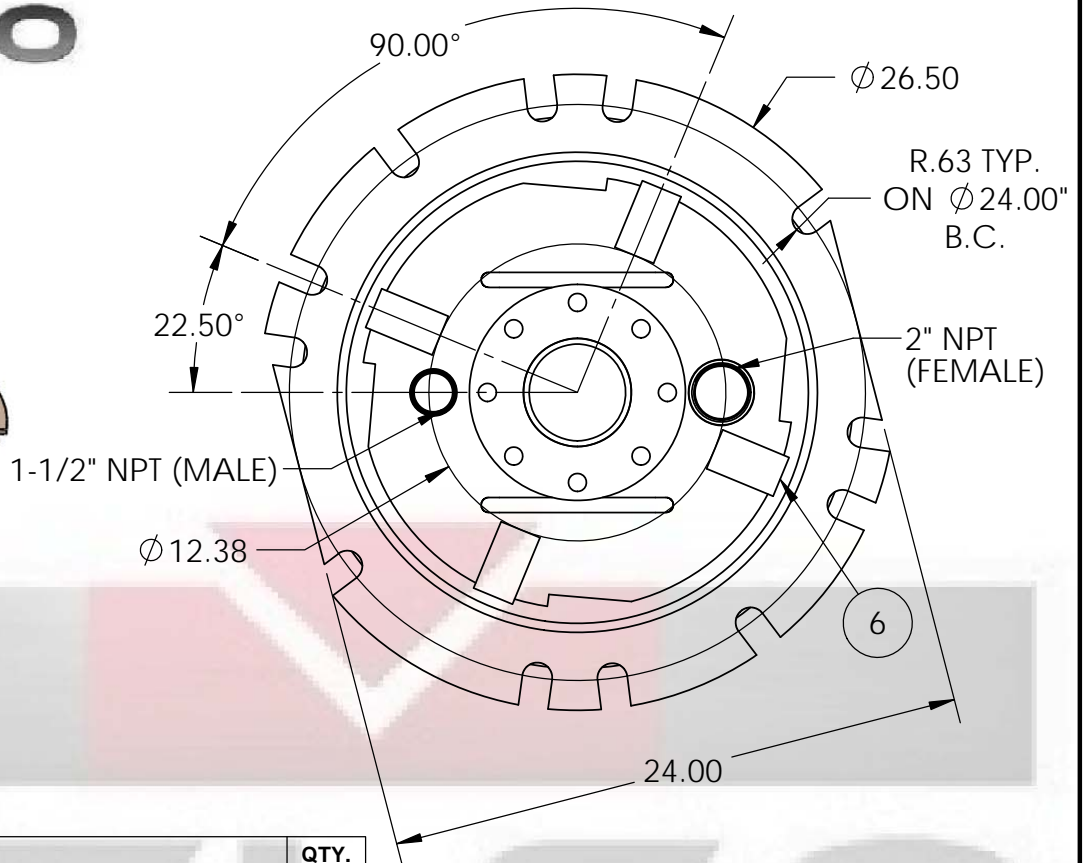

# Kelso Loading Adapter Plate Assembly Model # AP-AD

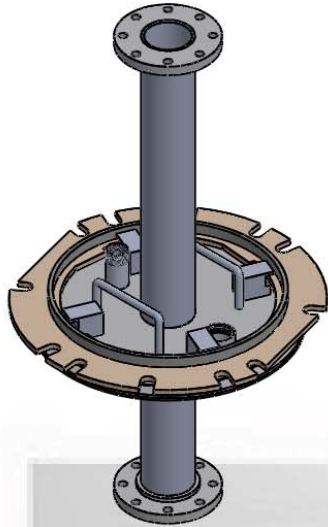

ITEM NO.	DESCRIPTION	QTY.
1	CORE PLATE FLANGED ASSEMBLY	1
2	GASKET (SEE NOTE)	1
3	GASKET RETAINER	1
4	1/4-20 X 3/4 HEX BOLT - SS	8
5	COVER PLATE LOCKING RING ASSEMBLY	1
6	LOCKING LUG	4

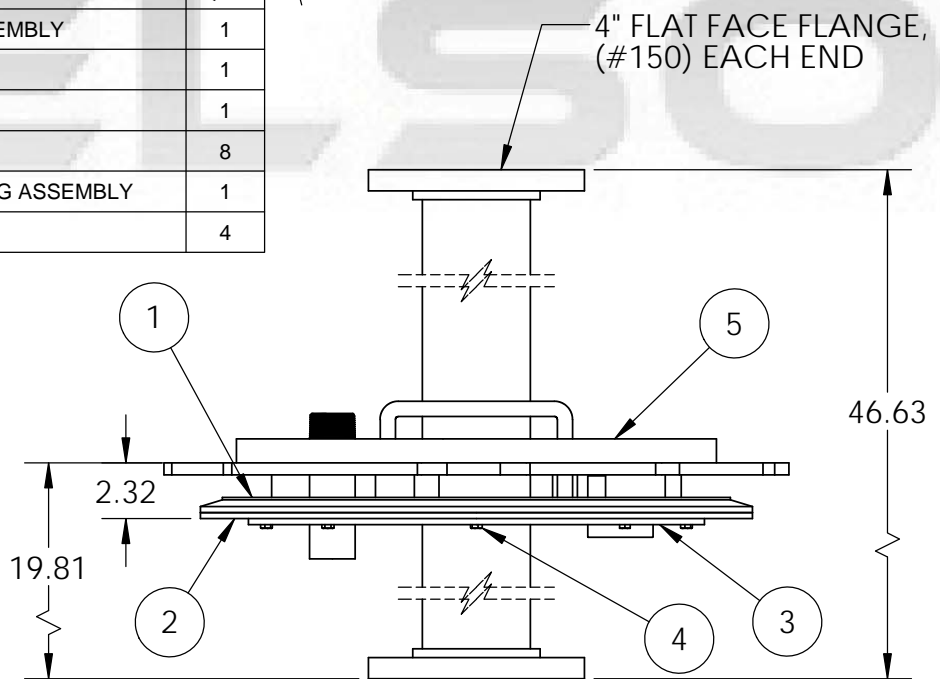

**Material:** Aluminum - 6061

**Weight:** 60LBS

**Note:** Mounting gasket not supplied.

**Gasket Dimensions:** 23" O.D. X 16" I.D. X .25" Width, (8X)  $\varnothing$  .31" holes on  $\varnothing$ 17.50" B.C. (REF)

*\*Other options are available: See document KTUD 1332 (Adapter Plate naming convention)*