

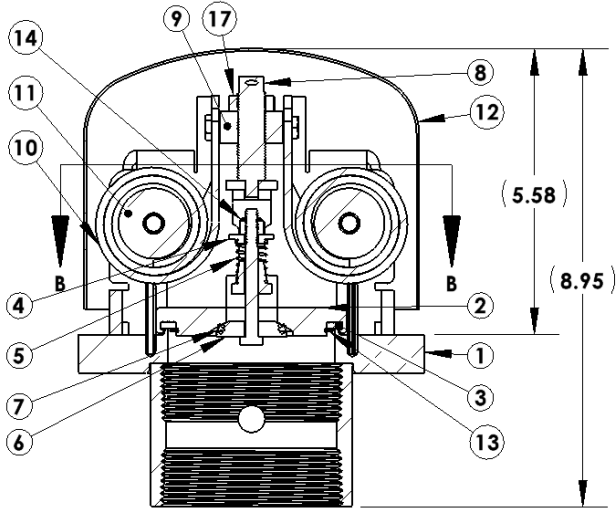

DOT 407 Pressure/Vacuum Relief Valve

KT30S-T3 Series



SECTION A-A

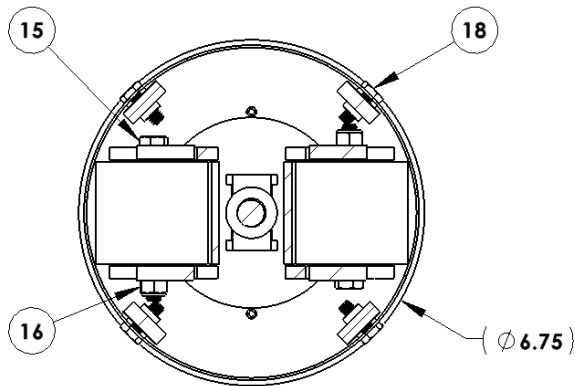

SECTION B-B

ITEMS 19 AND 20 NOT SHOWN FOR CLARITY

MAWP	30 psig
Set Pressure	36 psig
Set Vacuum Pressure	4" HG (-1.96 psig)
Flow Rate	2645 SCFM @ 45 psig
Orifice Diameter	3.25 inches
Weight	18 Lbs.
Attachment Method	3in. NPT

ITEM NO.	QTY.	DESCRIPTION	MATERIAL
1	1	BODY ASSEMBLY - 3" NPT COUPLING	STAINLESS STEEL
2	1	SEAL DISC ASSEMBLY	STAINLESS STEEL
3	1	TPV SEAL TABLE - PRESSURE	ELASTOMER*
4	1	SPRING PLATE	304 STAINLESS STEEL
5	1	VACUUM SPRING	302 STAINLESS STEEL
6	1	VACUUM STEM ASSEMBLY	STAINLESS STEEL
7	1	TPV SEAL TABLE - VACUUM	ELASTOMER*
8	1	ADJUSTMENT SCREW ASSEMBLY	STAINLESS STEEL
9	1	SPRING BLOCK	410 STAINLESS STEEL
10	2	6 LAMINATION SPRING - 2"	STAINLESS STEEL
11	2	SPRING DRUM	NYLON 6/6
12	1	TRUCK P-V VALVE COVER	304 STAINLESS STEEL 13 GA
13	1	SEAL RETAINER	316 STAINLESS STEEL
14	1	1/4-20 NE NYLON INSERT LOCK NUT (WAXED)	18-8 SS
15	2	HEX BOLT, 5/16-18 X 3.00, 18-8 SS	18-8 SS
16	2	NYLON INSERT NUT, 5/16-18, 18-8 SS	18-8 SS
17	1	JAM NUT, 9/16-18, 18-8 SS	18-8 SS
18	4	1/4-20 X 3/4 HEX BOLT	18-8 SS
19	2	#4-7 X 5/16" ROUND HEAD U-DRIVE SCREW	18-8 SS
20	1	KT30S-T3 NAMEPLATE	ALUMINUM

Notes:

- Valve features 2 ports on the side of the threaded connector: 3/4" NPT and 1/4" NPT
- Manufactured to 49CFR178.345-10
- Meets surge requirements per 49CFR178.345-10 (b) (3)
- *Seal Materials: Per Customer Request.

© 2021 Kelso Technologies (USA) Inc. All Kelso Relief Valves are Patent Protected. Detailed designs are subject to change without notice. Certified detailed drawings are available upon request.